

# Galvanised Triangular Stand

Part Number ST87

## Features

Commercial heavy-duty specification made from 48.3mm diameter tube with a strong 3mm wall thickness.

Fully hot dip galvanized after manufacture to BS EN ISO 1461 standard, ensures long lasting corrosion resistance.

All steel construction enables simple recycling at end of use.



## Options

Manufactured as surface mount bolt down or root fix version for embedding in concrete.

Stainless steel versions.

Galvanized finish.

DDA compliant Rilsan® eco coating available.

Powder coated to any RAL colour.

Reflective tape bands can be applied.

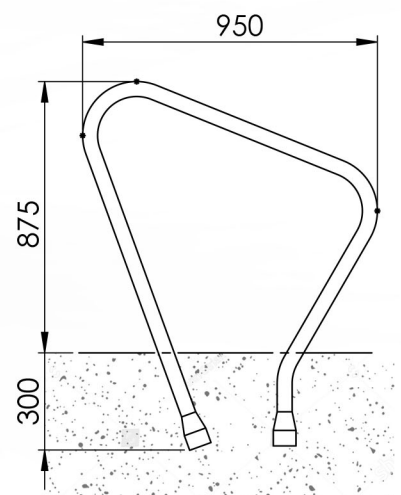
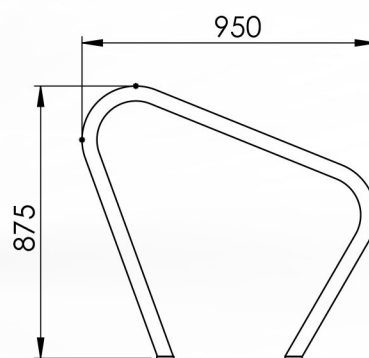

### Simbars UK Ltd.

46 Ashton Vale Rd,  
Bristol,  
BS3 2HQ  
tel: 0117 953 1444  
email: martin@simbars.co.uk  
www.simbars.co.uk