

# Galvanised M Stand

Part Number ST21

## Features

There are plenty of possibilities for secure locking points with this timeless classic.

Tough, Durable, Cost Effective, Secure Cycle Parking.

Commercial heavy-duty specification made from 48.3mm diameter tube with a strong 3mm wall thickness.

Fully hot dip galvanized after manufacture to BS EN ISO 1461 standard, ensures long lasting corrosion resistance.

All steel construction enables simple recycling at end of use.

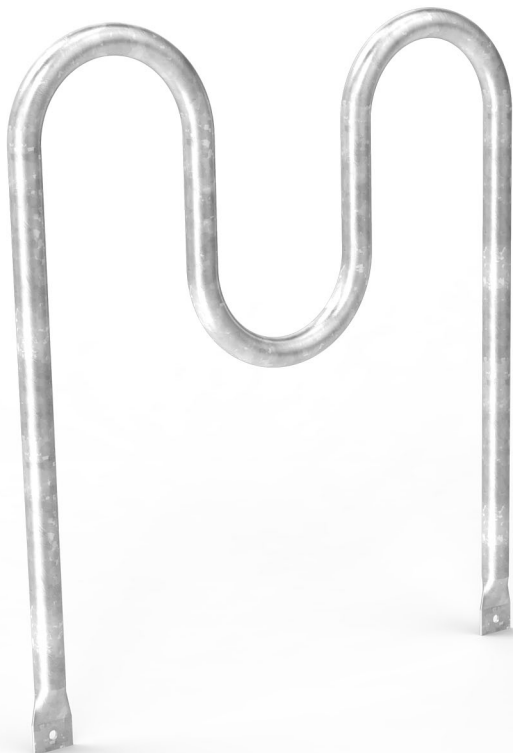

## Options

Manufactured as surface mount bolt down or root fix version for embedding in concrete.

Powder coated to any RAL colour.

DDA compliant Rilsan® eco coating available.

Reflective tape bands can be applied.

Stainless steel versions.

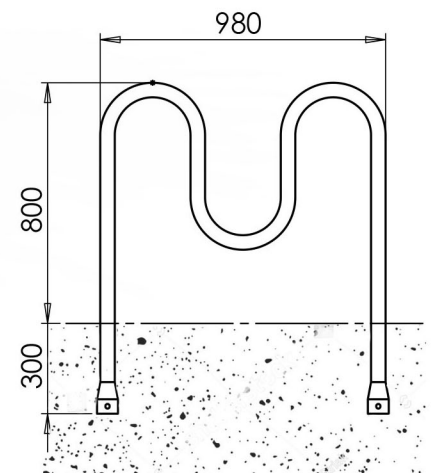
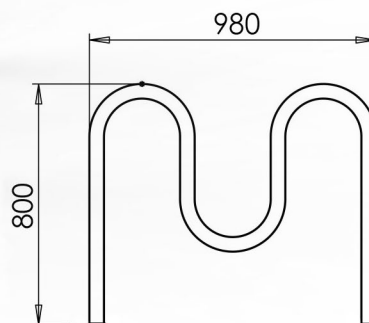

### Simbars UK Ltd.

46 Ashton Vale Rd,  
Bristol,  
BS3 2HQ

tel: 0117 953 1444

email: martin@simbars.co.uk

www.simbars.co.uk