

# Stainless Steel Slope Stand

Part Number ST20

## Features

A popular choice and especially effective where space is limited.

Commercial heavy-duty specification made from 50.8 mm diameter tube with a strong 2mm wall thickness.

Fine satin brushed finish to Ra.5 as standard.

Stainless steel construction ensures simple recycling at end of use.



## Options

Manufactured as surface mount bolt down or root fix version for embedding in concrete.

Stainless steel grade 304 or 316.

Bright polish finish.

DDA compliant Rilsan® eco coating available.

Galvanized finish.

Powder coated to any RAL colour.

Reflective tape bands can be applied.

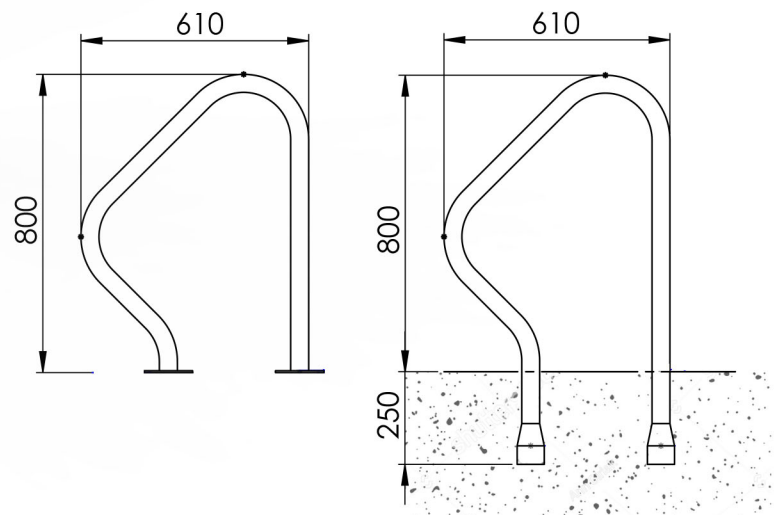

## Simbars UK Ltd.

46 Ashton Vale Rd,  
Bristol,  
BS3 2HQ  
tel: 0117 953 1444  
email: martin@simbars.co.uk  
www.simbars.co.uk