

Rilsan® Coated Slope Stand

Part Number ST20

Features

A popular choice and especially effective where space is limited.

Commercial heavy-duty specification made from 48.3mm diameter tube with a strong 3mm wall thickness.

Rilsan® PA11 nylon coating is forgiving, energy absorbing and therefore non damaging to cycle frames. It is also a DDA compliant finish being “warm to the touch”.

Rilsan® nylon provides the perfect long-lasting, abrasion resistant coating with durable corrosion protection.

The steel used in the manufacture of our cycle stands is readily recycled at the end of use.



Options

Manufactured as surface mount bolt down or root fix version for embedding in concrete.

Stainless steel versions.

Galvanized finish.

Powder coated to any RAL colour.

Reflective tape bands can be applied.

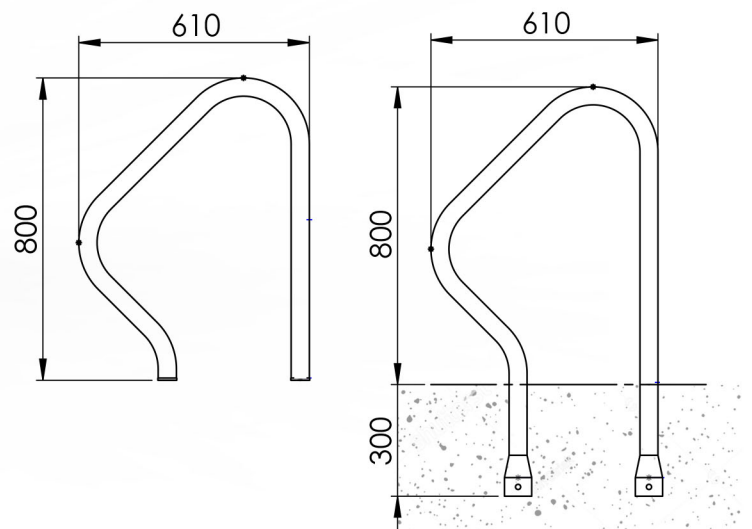

Simbars UK Ltd.

46 Ashton Vale Rd,

Bristol,

BS3 2HQ

tel: 0117 953 1444

email: martin@simbars.co.uk

www.simbars.co.uk