

# Stainless Steel Tulip Stand

Part Number ST16

## Features

A unique design concept that not only looks amazing but also functions well as a cycle stand. Both wheels can be locked ensuring a high level of security.

Commercial heavy-duty specification made from 50.8 mm diameter tube with a strong 2mm wall thickness.

Fine satin brushed finish to Ra.5 as standard.

Stainless steel construction ensures simple recycling at end of use.



## Options

Manufactured as surface mount bolt down or root fix version for embedding in concrete.

Stainless steel grade 304 or 316.

Bright polish finish.

DDA compliant Rilsan® eco coating available.

Galvanized finish.

Powder coated to any RAL colour.

Reflective tape bands can be applied.

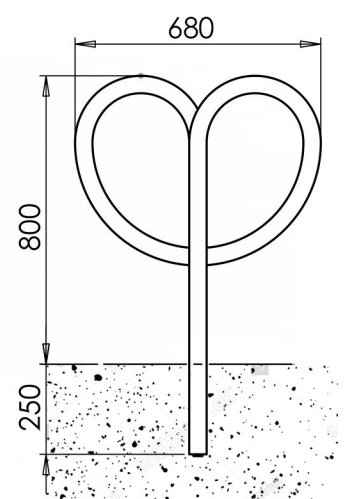
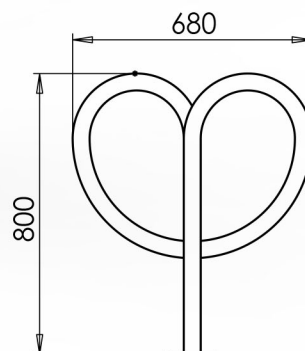

### Simbars UK Ltd.

46 Ashton Vale Rd,  
Bristol,  
BS3 2HQ

tel: 0117 953 1444

email: martin@simbars.co.uk

www.simbars.co.uk