

Galvanised Hoop Stand

Part Number ST05

Features

An alternative to sheffield stands a rolled top hoop stand offers the same high level of cycle security.

Commercial heavy-duty specification made from 48.3mm diameter tube with a strong 3mm wall thickness.

Fully hot dip galvanized after manufacture to BS EN ISO 1461 standard, ensures long lasting corrosion resistance.

All steel construction enables simple recycling at end of use.

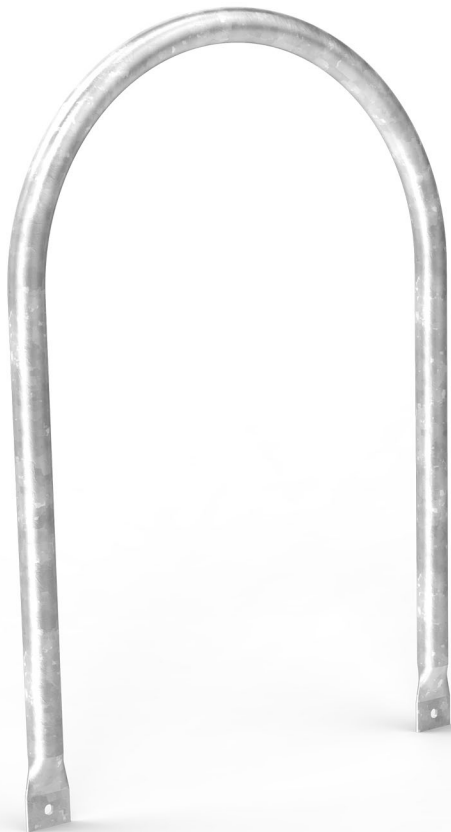

Options

Manufactured as surface mount bolt down or root fix version for embedding in concrete.

Cross rails (tapping tubes) can be added.

Powder coated to any RAL colour.

DDA compliant Rilsan® eco coating available.

Reflective tape bands can be applied.

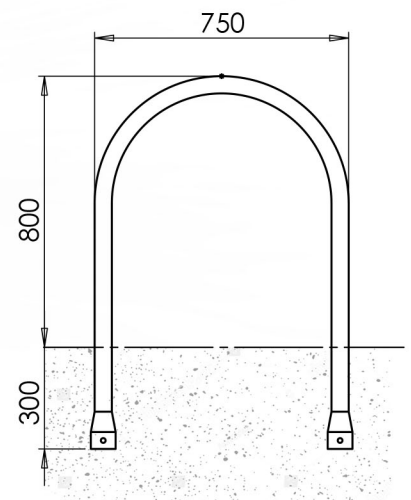
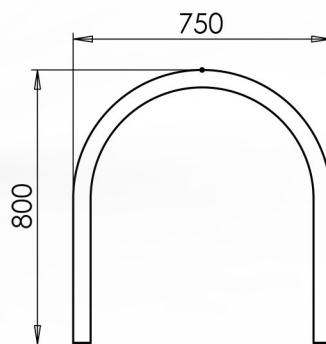

Simbars UK Ltd.

46 Ashton Vale Rd,
Bristol,
BS3 2HQ
tel: 0117 953 1444
email: martin@simbars.co.uk
www.simbars.co.uk